

PILOT CHECK VALVES

IPCC-SCJJ

HYDRAULIC DIAGRAM

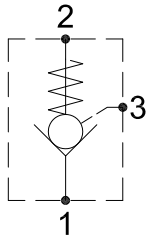

Type	Qnom (L/min)	Pmax (Bar)
IPCC-SCJJ	260	350

RATING DIAGRAM

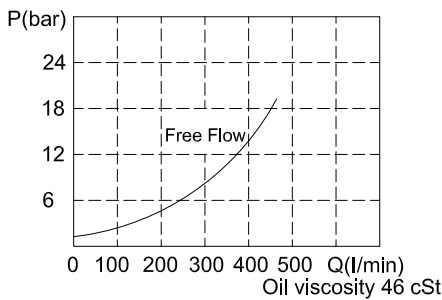

DIMENSIONS (mm)

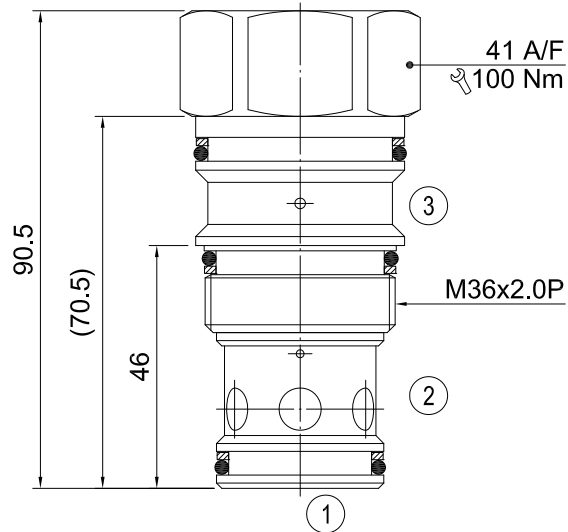

Cavities: see cavity data ST17A

CODE NUMBER

IPCC-SCJJ-P2

Pilot Ratio 2:1

■ APPLICATION

Pilot pressure closes the check valves and allows flow to pass in one direction. And low pressure drop prevents reverse flow. The generated pilot pressure prevents flow from free flow. The pilot ratio is 2:1 and allows a lower pressure drop in pilot line to hold the valve closed.

■ OPERATION

Oil flow is permitted from port 1 to port 2 and closed to prevent flow in the reserve direction. After the pilot pressure (port 3) is generated, there's no flow from port 2 to port 1, and can't flow from port 1 to port 2.

■ PERFORMANCE

Rated Flow : 260 l/min Max. pressure : 350 bar
 Leakage : 0.3 ml/min (5 dpm)
 Working temperature :
 Min. -20°C, Max. 90°C, with standard BUNAN gaskets
 Min. -20°C, Max. 120°C, with optional VITON gaskets on request

■ RECOMMENDATIONS

Fluid: best use mineral oil with viscosity ranging between 10 and 200 cSt
Filter: 25 micron or better
Cavities: see cavity data ST17A
Installation: before screwing the cartridge on the valve body, ascertain to provide suitable gasket lubrication with clean oil and also be sure to screw the cartridge manually in to reach against the gaskets in the valve body.